

HDCVI PIR Camera User's Manual

Version 1.0.1

Table of Contents

1	General Introduction	1
1.1	Overview	1
1.2	Features	1
2	Device Framework	2
3	Detection Range	4
4	Device Installation	5
5	Product Application	6
6	Menu	7
6.1	HCVR Settings	7
6.2	Menu Operation	7
	Appendix I Technical Parameters	9
	Appendix 2 Maintenance	10

Welcome

Thank you for purchasing our HDCVI PIR camera!

This user's manual is designed to be a reference tool for your system.

Please read the following safeguard and warnings carefully before you use this series product!

Please keep this user's manual well for future reference!

Important Safeguards and Warnings

1 . Electrical safety

- All installation and operation here should conform to your local electrical safety codes.
- The power shall conform to the requirement in the SELV (Safety Extra Low Voltage) and the Limited power source is rated DC 12V in the IEC60950-1. (Power supply requirement is subject to the device label).
- Please install easy-to-use device for power off before installing wiring, which is for emergent power off when necessary.
- Please check if the power supply meets the requirements of working voltage of the camera before operating the device (The material and length of the power supply cable will influence terminal voltage value).
- Please prevent the line cord from being trampled or pressed, especially the plug, power socket and the junction from the device.

2 . Environment

- Please don't aim the device at strong light (such as lighting, sunlight and so on) to focus.
- Please transport, use and store the device within the range of allowed humidity and temperature.
- Please do not allow water and other liquid falling into the camera in case that the internal components are damaged.
- Please keep the sound ventilation in case of heat accumulation.
- Heavy stress, violent vibration or water splash are not allowed during transportation, storage and installation.
- Please pack the device with standard factory packaging or material with same quality when transporting the device.
- It is recommended to use the device together with lightning protection device to enhance lightning protection effect.
- It is recommended to GND the device to enhance device reliability.
- It is advised to use qualified video transmission cable to improve video quality. It is recommended to use RG59 coaxial cable or higher standard.

Warning

- Please use the standard accessories provided by manufacturer and make sure the device is installed and fixed by professional engineers.
- Please prevent the device surface from the radiation of laser beam when using laser beam device.

- Please do not provide two or more power supply modes for the device, otherwise it may cause damage to the device.

Statement

- Please refer to the actual product for more details; the manual is just for reference.
- The manual will be regularly upgraded according to the product update; the upgraded content will be added in the manual without prior announcement.
- Please contact the customer service for the latest procedure and supplementary documentation.
- The company is not liable for any loss caused by the operation which is not followed by the manual.
- Please refer to the company's final explanation if there is any doubt or dispute.

1 General Introduction

1.1 Overview

This series HDCVI camera conforms to the HDCVI standard. It supports video signal high-speed, long distance transmission without any delay. It can be controlled by the HCVR conforming to the HDCVI.

1.2 Features

- Adopt high performance CMOS image sensor, megapixel definition.
- Support coaxial transmission of HD video and control signal.
- For 720P series, support RG59 coaxial cable transmission without any loss. The distance is over 800m. For 1080P series, support RG59 coaxial cable transmission without any loss. The distance is over 500m.
- High speed, long distance real-time transmission.
- Support HD/SD output.
- Support OSD menu adjusting parameters.
- Support DC 12V power supply.
- Adopt dual digital sensor, efficiently improve detection accuracy.
- One-step detection technology, detection sensitivity adjustable.
- Digital white light resistance interference technology, white light resistance $\geq 6500\text{LUX}$.
- Digital temperature compensation technology, adapt to the environmental change.
- Detection distance: 12m, detection angle: 100° .
- Default bracket, support wall-mounted installation mode.
- Support tamperproof for device cover.
- Communication frequency 433MHz, communication distance 1km (open distance).

2 Device Framework

Please see Figure 2-1 for the dimensions. The unit is mm.

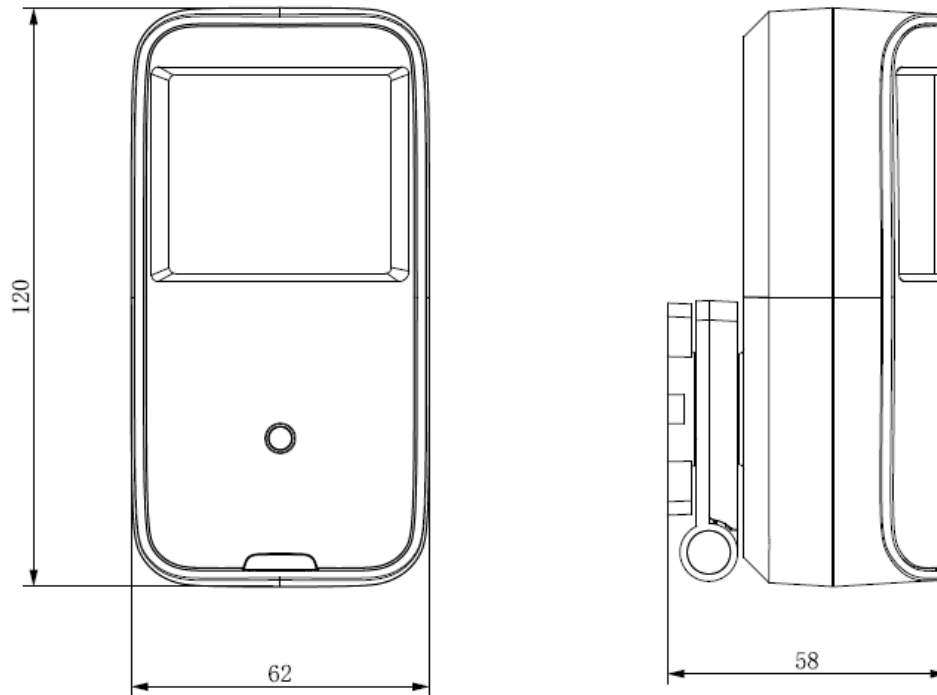

Figure 2-1

Please see Figure 2-2 for the device structure and components.

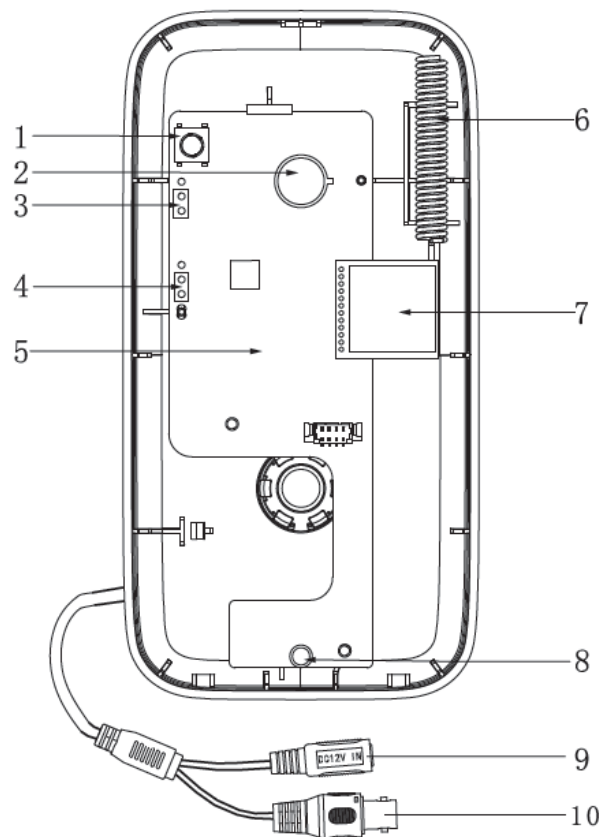

Figure 2-2

Please refer to the following sheet for more details.

SN	Name
1	Tamper switch
2	Heat release IR sensor
3	Sensitivity adjustment bouncing pin
4	LED bouncing pin
5	PCB
6	Antenna
7	Wireless module (Optional)
8	LED
9	Power input port
10	Video output port

3 Detection Range

The detection range of the detector is shown in Figure 3-1 (top view), the horizontal angle of detection is 100° .

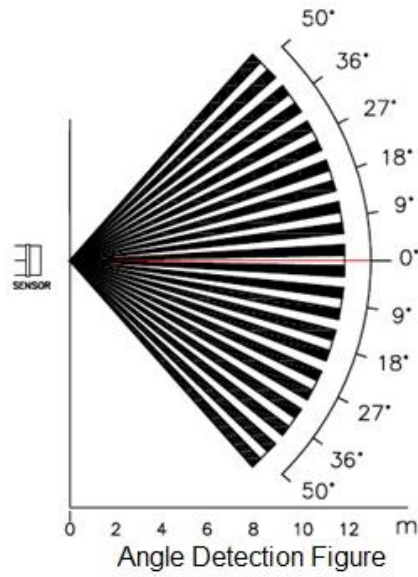

Figure 3-1

The detection range of the detector is shown in Figure 3-2 (side view), the far distance of detection is 12m while the near distance is 1m. The bracket supports omnidirectional rotation.

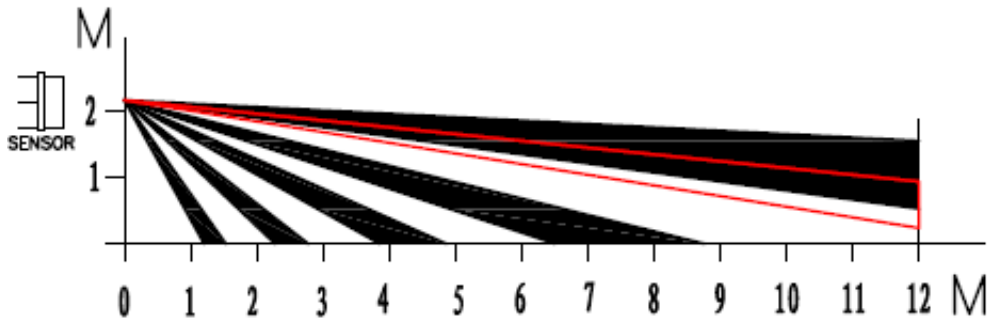

Figure 3-2

Note:

The angle of detector can be adjusted according to the practical application scenario.

4 Device Installation

Attention:

- Engineering installation and debugging have to be implemented by professional team, please do not dismantle or repair in case of device malfunction, you can contact the after-sale department for more information.
- Try not to install the device in a location with direct sunlight.
- Try not to install the device in a location with fast change of wind speed.
- Try not to install the device in a location with too high temperature.
- Try not to install the device in a detection range where it is blocked.
- Try not to install the device in a location where there is large-scale metal product.

The installation steps of the device are shown as follows:

Step 1

Rotate the camera installation bracket for 90° , which is shown in Figure 4-1.

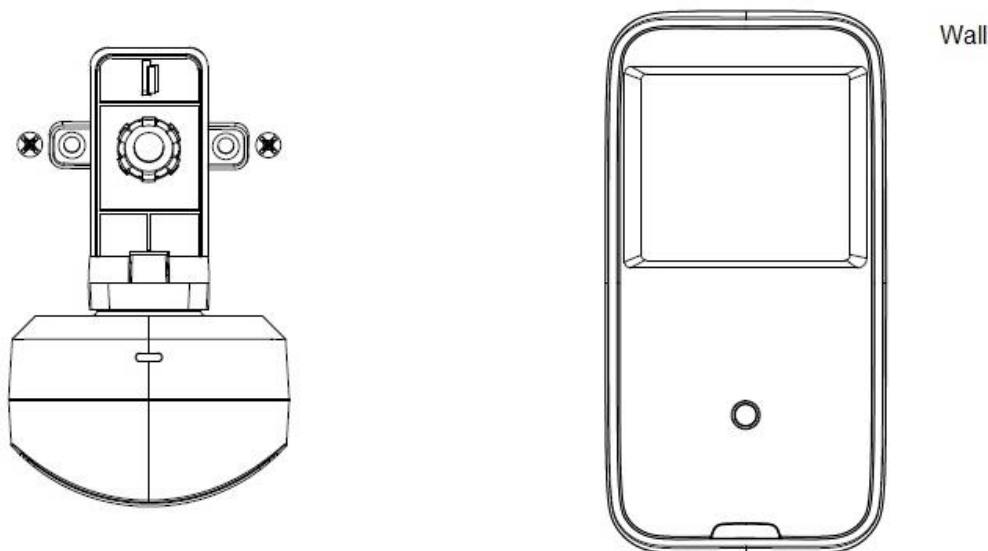

Figure 4-1

Step 2

During installation, make sure the installation bracket bottom is parallel with the wall, pull the cable from the outlet groove of the installation surface and use screws to fix the camera with the wall via bracket installation hole.

Step 3

Adjust the monitoring direction of camera.

Step 4

Connect the video output port of the device to the back-end HCVR device, and connect the power port to power.

So far, the device installation and cable connection are completed, then you can check the device monitoring image via rear-end encoding device.

5 Product Application

Network Access (only for –W model)

It needs to set network access of the detector before normally using wireless PIR intrusion detector.

There are two modes for network access of detector:

- Connected via wireless alarm programming keyboard

It needs to enable connection mode on the keyboard in this mode, and then power on the detector, at this moment the indicator light of the detector is normally on, slide the tamper switch and the indicator light starts to flash. After waiting for around 10 seconds, if the indicator light is off, then it means the detector connection is successful; it means connection failure if the indicator light slowly flashes for three times, then you need to repeat the above steps to get access to network.

- Connection via setting MAC address

In this mode, it needs to set the detector MAC address into the MAC address list of wireless alarm controller via keyboard or client, and then power on the detector. After waiting for around 40 seconds, if the indicator light is off, then it means the detector connection is successful.

Note:

If the detector has been connected to other alarm controllers, then it can clear previous connection information by quickly sliding tamper switch (5 times within 1 second).

LED Setting

You can control the status of LED indicator light via setting LED bouncing pin, there are two statuses of LED indicator light, which are on or off. You can set two types of value for the bouncing pin, which are 1&2 and 2&3. It is LED OFF when selecting 1&2 and it is LED ON when selecting 2&3; the factory default setting is LED ON.

Note:

The operation causes no influence to normal work of the detector.

Pulse Count Setting

You can set pulse count bouncing pin according to the product application environment or detection distance requirement. You can set two types of value for bouncing pin, which are 1&2 and 2&3, it is first pulse when selecting 1&2 and it is second pulse when selecting 2&3, the factory default setting is 1P. The detection sensitivity of 1P is high and the detection sensitivity of 2P is low.

Installation Test

You can test the working state of the detector; the exact operation is shown as follows: Within the detection range, it is to test with normal walk speed of 1m/s. It means IR is triggered when the red indicator light continues to be on for 2 seconds, the detector will get into the alarm status, output alarm signal, at this moment the red indicator light is on. If the motion detection is enabled at this moment, then alarm can be generated on DVR, it can also receive alarm info if it is equipped with wireless mobile portable terminal.

6 Menu

6.1 HCVR Settings

This HDCVI camera series can adjust OSD menu via coaxial control. After connected the camera to the HDCVI series HCVR, from Main Menu->Setting->System->PTZ, you need to select the channel number for access and set control mode as HDCVI and the protocol as HD-CVI. Click “Save” button to save current setup. See Figure 6-1.



Figure 6-1

6.2 Menu Operation

Click the right mouse button and select “PTZ Control”, then you will see the “PTZ Setup” menu, which is as shown in Figure 6-2 and Figure 6-3.



Figure 6-2



Figure 6-3

See Sheet 4-1 for the details of button functions.

Button	Function	
	Open menu	
,	Select menu item	
,	Select menu value	
Zoom	Adjust lens zoom and auto trigger focus	Note: Some of the buttons can only be applied for the motorized vari-focal camera.
Focus	Adjust lens focus	
Iris	Auto focus under current zoom rate	
	Lens reset	

Sheet 6-1

If there is “↵”, click the “Confirm” button in “Menu Operation” interface to go to the 2nd menu. Click “Return” button to go back to the previous menu interface.

Appendix I Technical Parameters

Parameter	Note
Detection Method	Dual PIR
Detection Range	12m, 100°, 13 areas
Alarm Indication	Red LED, it can set OFF.
Sensitivity	Two level (jumper cap)
Carrier Frequency	433MHz
Transmitting Power	10dBm
Transmission Distance	1km (Open space/no disturbance)
Pet immunity	≤18kg
White Light Resistance	6500 LUX
Tamperproof	Support device tamperproof
Installation Height	2.2m~2.5 m
Installation Mode	Wall mount
Dimension	120x62x58mm (lengthxwidthxheight)
Weight	0.15kg
Operation Temperature	-10°C~50°C
Operation Humidity	< 95%

Appendix 2 Maintenance

Attention:

Please maintain the device according to the following instructions in order to ensure the image effect and long-term stable operation of the device.

Maintenance for lens and mirror surface

The lens and mirror surface are covered with antireflection coating, so it may produce hazardous substance and lead to performance reduction or scratch, dimness etc. when it is stained with dust, grease, fingerprint and so on, please refer to the following methods to deal with once dirt is found:

Stained with dirt

Use oil-free soft brush or hair dries to remove it gently.

Stained with grease or fingerprint

Use soft cloth to wipe the water drop or oil gently to make it dry, then use oil-free cotton cloth or paper soaked with alcohol or detergent to wipe from the lens center to outward. It is ok to change the cloth and wipe several times if it is not clean enough.

Camera Body Maintenance

Use a soft dry cloth to clean the camera body when it is dirty, in case the dirt is hard to remove, use a clean dry cloth soaked with mild detergent and wipe gently, make it dry later. Don't use volatile solvent like alcohol, benzene, thinner and etc or strong detergent with abrasiveness, otherwise it will damage the surface coating or reduce the working performance of the device.

Maintenance for Dome Cover

Dome cover is an optical device, please don't touch or wipe cover surface directly during installation and use, please refer to the following methods to deal with once dirt is found:

Stained with dirt

Use oil-free soft brush or hair dries to remove it gently.

Stained with grease or fingerprint

Use soft cloth to wipe the water drop or oil gently to make it dry, then use oil-free cotton cloth or paper soaked with alcohol or detergent to wipe from the lens center to outward. It is ok to change the cloth and wipe several times if it is not clean enough.

Note

- **This manual is for reference only. Slight difference may be found in the user interface.**
- **All the designs and software here are subject to change without prior written notice.**
- **All trademarks and registered trademarks mentioned are the properties of their respective owners.**
- **If there is any uncertainty or controversy, please refer to the final explanation of us.**
- **Please visit our website or contact your local service engineer for more information.**